

SPECIFICATIONS

Models with Mechanical Chucking		A15	A25	A32	A42	A60	TD26	TD36	TB42	TB60	THU25	THU32
Models with Hydraulic Chucking							TDF26		TBF42			
Max. Spindle capacity for round bars	mm	15	25	32	42	60	26	36	42	60	25	32
for hexagonal bars	mm	12	22	27	36	52	22	30	36	52	22	27
for square bars	mm	10	18	22.5	29	42	18	25	29	42	18	22.5
Distance from collet to face of tailstock	mm	240	240	240	396	396	285	285	400	400		
Turning length with front longitudinal turning attachment	mm	70	70	70	100	100	70	70	100	100	70	70
Spindle revolutions, max	RPM	6500	4000	4000	2500	2000	4750	4000	2000	1600	3050	3050
Output adjustable From	sec/pc	1.71	1.71	1.71	2.89	2.89	1.91	1.91	3.7	3.7		
To	sec/pc	128	128	128	300	300	230	230	360	360		
Nominal power	kw	1.2/1.6	1.2/1/6	2/2.4	2.2/2.8	2.2/2.8	1.5/2.2	1.5/2.2	2.9/4.3	2.9/4.3	0.37/1.0	0.37/1.0
Vertical toolholder slides stroke	mm	15/22	15/22	15/22	30	30	35	35	40	40	25	25
Horizontal toolholder slides stroke	mm	11/22	11/22	11/22	28	40	35	35	40	40	60	60
Net weight	kg	560	560	600	1200	1200	1200	1200	1460	1460	375	400
Dimensions without bar feeder (L x W x H)	mm	1350x670x1690	1500x900x1690	1500x900x1690	2350x970x1650	2350x970x1650	1910x1220x1980	1910x1220x1980	1350x670x1690	1350x670x1690	2350x970x1650	2350x970x1650

Specification are subject to change without notice for continuous development. Other details and features on request.



PIIT MACHINES LIMITED

Head Office & Works : P.O.Box No. 1102, Behind PCMC Building, Mumbai-Pune Road, Pimpri, Pune - 411 018 (India)
 Tel. No.- +91-20-27426219 to 23 E-mail - rd@pmtmachines.com, marketing@pmtmachines.com | Website - www.pmtmachines.com
 Halol Works : 178, Kadachala, Halol - 389350. Gujarat (India) Tel. No.- +91-02676-246786/87
 E-mail - cb@pmtmachines.com, mkt.brd@pmtmachines.com



Sales and Service Network

MUMBAI	Mobile. No - 98217 13400 93217 13400	E-mail - pmtmumbai@pmtmachines.com pmtmumbai@gmail.com
NEW DELHI	Mobile. No - 98104 01815	E-mail - pmtdelhi@pmtmachines.com
BANGALORE	Mobile. No - 99860 48173	E-mail - pmtbangalore@pmtmachines.com pmtbangalore6@gmail.com
CHENNAI	Mobile. No - 98401 02157	E-mail - pmtchennai@machines.com pmtmadras02@gmail.com
COIMBATORE	Mobile. No - 98403 66822	E-mail - pmtcbe@gmail.com
JAMSHEDPUR	Mobile. No - 99341 19234	E-mail - dalbir34singh@rediffmail.com pmtjsr@gmail.com
VADODARA	Mobile. No - 96625 03927	E-mail - mkt.brd@pmtmachines.com
KOLKATA	Mobile. No - 70034 85126	E-mail - pmtkolkata@gmail.com
KOLHAPUR	Mobile. No - 97305 76789	E-mail - ssd@pmtmachines.com

PIIT MACHINES

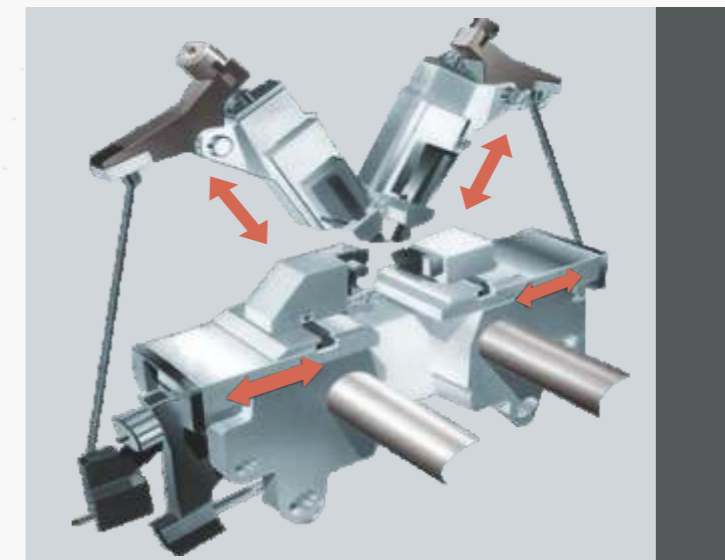

SINGLE SPINDLE AUTOMATIC LATHES

AUTOMATS
SINGLE SPINDLE CAM LATHES

Building on the strong German Foundation



A 15 / 25



A 42 / 60



A 25 CE

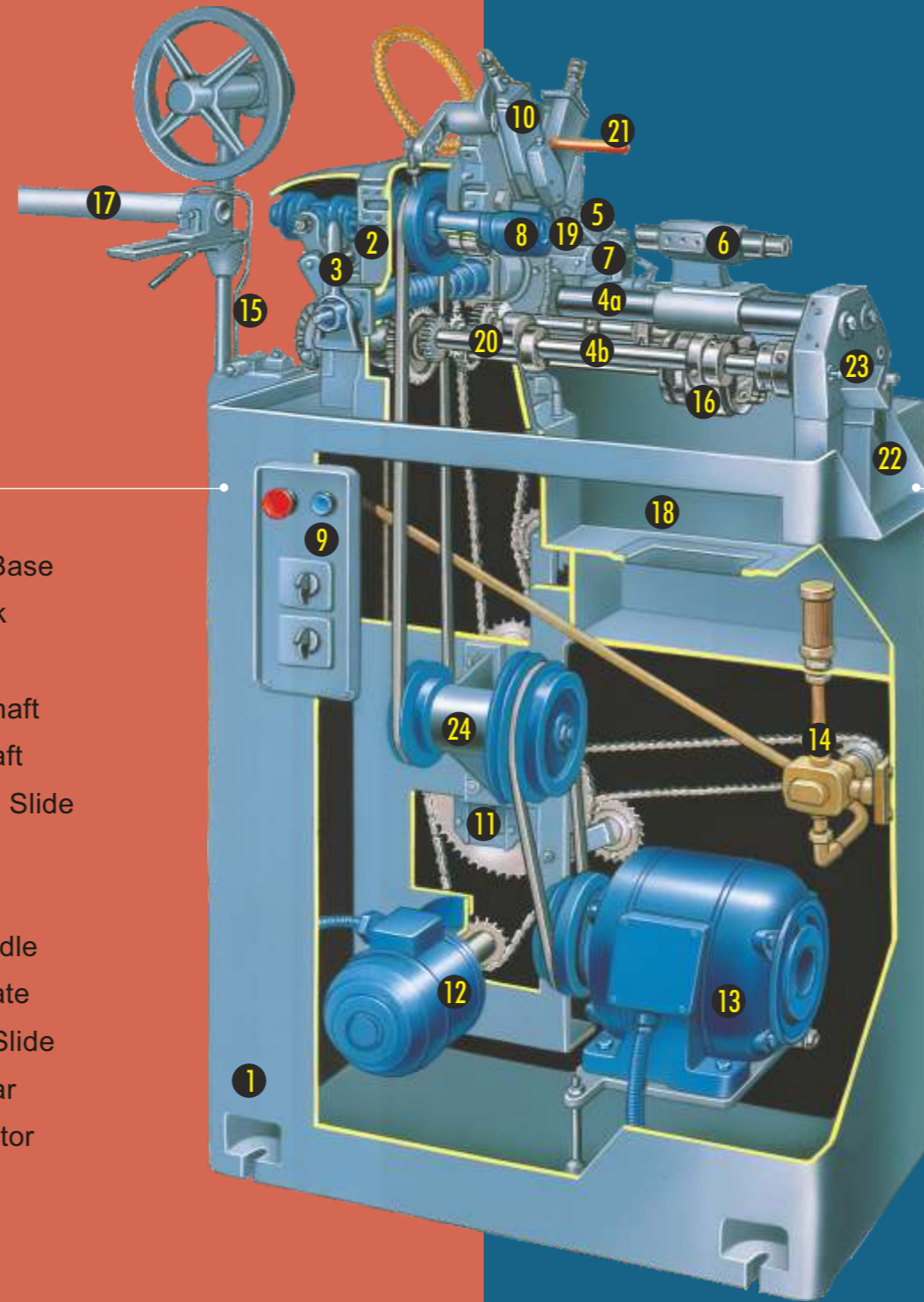

- 1. Machine Base
- 2. Headstock
- 3. Clutch
- 4a. Guide Shaft
- 4b. Cam Shaft
- 5. Horizontal Slide
- 6. Tailstock
- 7. Bar Stop
- 8. Main Spindle
- 9. Switch Plate
- 10. Vertical Slide
- 11. Feed gear
- 12. Feed motor

- 13. Main motor
- 14. Coolant pump
- 15. Auto shut down
- 16. Drilling camdrum
- 17. Bar feed
- 18. Chip Tray
- 19. Spindle collet
- 20. Control cams
- 21. Coolant line
- 22. Chip Chute
- 23. Workpiece Counter
- 24. Counter shaft



TD 26 / 36



TB 42 / 60



THU 25 / 32



Double Drilling and Threading Attachment



Longitudinal Turning Attachment

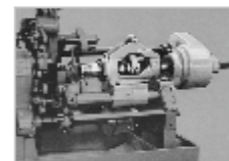

Synchronized Drive Attachment



Long Turning Attachment Front and Rear



Turret



Double Vertical Slide



Thread Chasing Attachment



Thread Cutting Attachment



Four Position Turret



Thread-Milling Attachment



Double Vertical Slide



Pickup Attachment



Spindle Gear Box



Thread Chasing Attachment



Thread milling



High Speed drilling Attachment with Fixed Quill